

Miggytrac 1001

The perfect complement to your MIG power source

The Miggytrac 1001 is a superb alternative if you wish to automate your GMAW process.

The Miggytrac is ideal for use with ESAB's semi-automatic power sources and feed units.

The Miggytrac 1001 is a small, compact, motor powered tractor to which a standard ESAB welding torch can be attached quickly. The four driving wheels, together with the permanent magnet which is fitted on the tractor, guarantee an even, stable movement. The magnet holds the tractor in the correct position on the work-piece, even if it is bent or angled and follows the joint using guide wheels, which can be adjusted to allow the unit to drive itself against the workpiece.

The tractor functions as a straightforward remote control for the feed unit; you decide on the travel direction, then start and stop welding from the panel. The panel features additional functions such as travel speed settings (150-1200 mm/min), wire feed speed, voltage, voltage and welding on/off.

Cored-wire welding - a process in keeping with the times
It is easy to mechanize a semi-automatic welding machine using the Miggytrac 1001. The welding speed can be increased significantly, especially when cored wire is used.

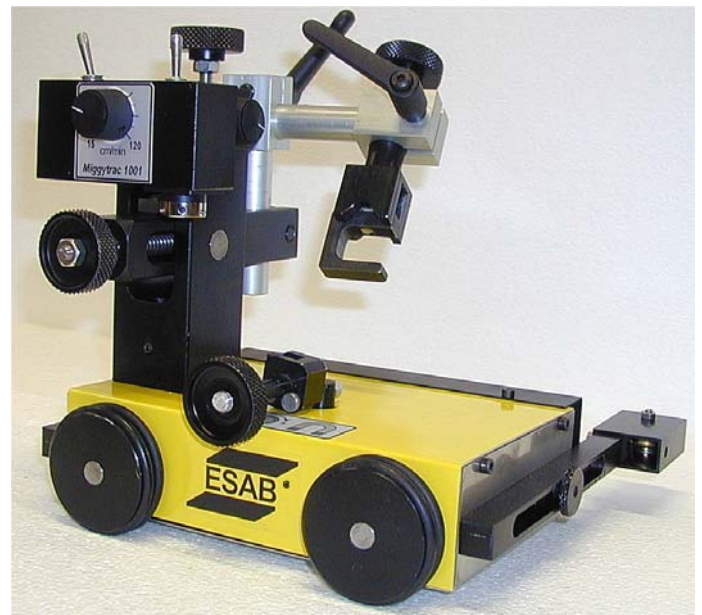

Simply connect the tractor to a suitable semi-automatic power source with a feed unit.

Alternatively, an external source can be connected. The automatic welder performs the long and monotonous weld runs.

The torch holder
The torch holder is equipped with two manual slides for fine corrections of the torch position. The torch holder has also a rotating slide which gives maximum opportunities to get the best possible torch angle.

Technical data

Control voltage	36 - 46 V AC
Power	20 W
Welding speed	150 -1200 mm/min
Remote control outlet	Volt and ampere (wire feed speed)
Connection	Burndy, 12 pins
Dimensions (LxWxH)	266x257x267 mm
Weight	7 kg

Ordering information

Miggytrac 1001	0457 357 881
Welding screen	0457 463 880

CABLE KEY DIAGRAM												
Feeder unit	Brand	0457 360 880	0457 360 881	0457 360 883	0457 462 880	0443 341 880	0459 681 880	0457 467 880	Voltage	Current	Power	On/Off
Origo™ Feed 304; M12	ESAB	X							-	X	X	X
Origo™ Feed 484; M12		X							-	X	X	X
Origo™ Feed 304; M13		X							X	X	X	X
Origo™ Feed 484; M13		X							X	X	X	X
Aristo™ Feed 3004, 4804		X					X		X	X	X	X
MEK 4		X				X			X	X	X	X
MEH 44	ESAB			X		X			X	X	X	X
Universal	?		X					X	?	?	X	X
		Cable 23 pins	Cable without plug	Cable 4 pins + 12 pins	Cable kit	Connection kit	Remote adapter kit	Transformer				

Miggytrac 1001

Remote control of voltage and current only when connected to a suitable power source/wire feed unit.

The cable must be ordered as the cable key diagram shows.

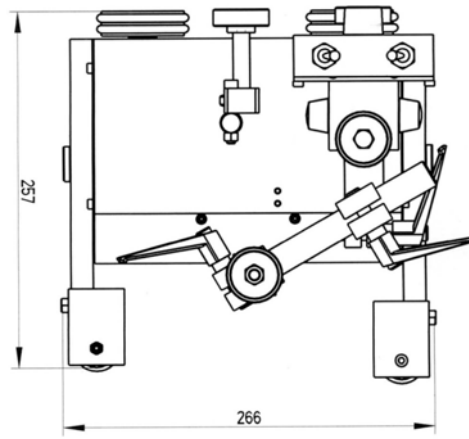
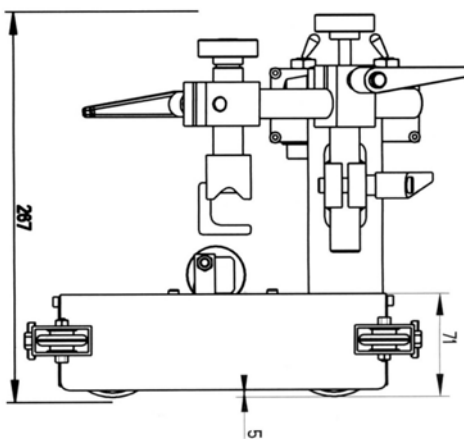

ESAB AB
 Welding Equipment
 SE-695 81 LAXÅ SWEDEN
 Phone: +46 584 81000
 Fax: +46 584 411721
 E-mail: info@esab.se
www.esab.com

